

Version
02.00December
2006

R&S® HL040 Log-Periodic Dipole Antenna

Broadband transmission and reception from 400 MHz to 3000 MHz – mobile and stationary use

The linearly polarized R&S® HL040 log-periodic dipole antenna provides broadband transmission and reception in the frequency range 400 MHz to 3000 MHz and can be used in the lab and for open-field applications.

- ◆ Suitable for field-strength and EMI measurements due to precise construction and customized calibration
- ◆ Compact design
- ◆ EMC measurements in the field of mobile radio
- ◆ Very low frequency dependence
- ◆ High polarization isolation
- ◆ Excellent front-to-back ratio
- ◆ Customized calibration in line with ANSI
- ◆ High symmetry of radiation patterns

**ROHDE & SCHWARZ**

Operation

For obtaining broadband characteristics, the R&S®HL040 antenna has a log-periodic dipole structure. The number of dipoles used in conjunction with a special feed line offers the following advantages when compared to other antenna configurations:

- ◆ Very low frequency dependence of radiation patterns and input impedance
- ◆ High symmetry of radiation patterns, i.e. the longitudinal axis of the antenna corresponds to the radiation or reception maximum; there is no annoying squint
- ◆ A polarization isolation of >20 dB permits accurate spatial determination of the electrical field vector
- ◆ High front-to-back ratio and therefore negligible effect of feed line and antenna support on antenna characteristics

Mobile and stationary use

The antenna can be mounted in two different ways:

- ◆ For mobile use, on a crank-type telescopic mast by means of the fastening elements provided on the mast
- ◆ For stationary use, to the M 8 × 8 threaded holes provided on the antenna flange

To prevent the accumulation of condensed water in the case of stationary use, the antenna must always be mounted with the correct side facing upward. Marks on the flange of the antenna show the correct antenna position with horizontal and with vertical polarization.

Made to last

The R&S®HL040 antenna is made of the following materials:

- ◆ Tinned brass for the dipoles
- ◆ Polypropylene for the antenna support
- ◆ Glass-fiber-reinforced plastic for the base plate
- ◆ Weatherproof aluminum for the antenna flange
- ◆ Colored glass-fiber-reinforced plastic for the radome protecting the antenna against environmental influences and resulting damage

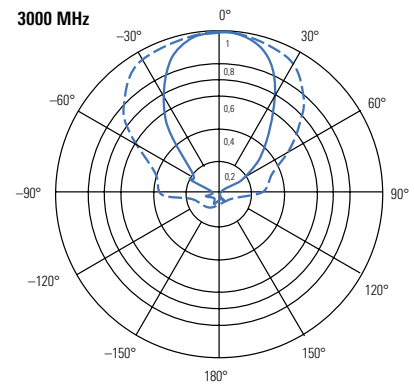
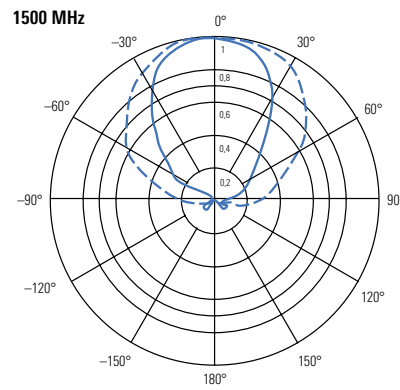
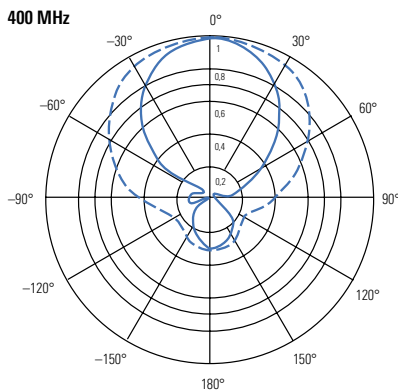

Measured radiation patterns of the R&S®HL040 log-periodic dipole antenna

Specifications

Frequency range	400 MHz to 3000 MHz
Polarization	linear
Impedance	50 Ω
SWR	<2.5, typ. <2.0
Gain	5 dBi to 7 dBi
Front-to-back ratio	
400 MHz to 450 MHz	>10 dB
450 MHz to 3000 MHz	>15 dB
Polarization isolation	>20 dB
RF connector	N female
Max. input power	150 W to 50 W (CW)
Dimensions (H \times W \times L)	130 mm \times 302 mm \times 680 mm (5.1 in \times 11.9 in \times 26.8 in)
Weight	2.8 kg (6.2 lb)
Color	RAL 7001/silver gray
MTBF	>150000 h
Environmental conditions	
Permissible wind speed	
Without ice deposit	200 km/h
With 6.4 mm radial ice deposit	118 km/h
Operating temperature range ¹⁾	-40 °C to +70 °C
Storage temperature range ¹⁾	-51 °C to +71 °C
Relative humidity ¹⁾	95% at max. +55 °C
Resistance to salt mist, sand and dust	MIL-STD-810 D
Class of protection ²⁾	IP53
Shock ³⁾	MIL-STD-810 D
Vibration ³⁾	random
Fastening elements	flange for crank-type telescopic mast

¹⁾ Test specification MIL-T-28800D.

²⁾ Applicable during operation (antenna horizontal or vertical).

³⁾ Applicable during transport (antenna lying flat).

Ordering information

Designation	Type	Order No.
Log-Periodic Dipole Antenna	R&S®HL040	4035.8755.02



More information at
www.rohde-schwarz.com
(search term: HL040)



ROHDE & SCHWARZ

www.rohde-schwarz.com

Europe: +49 1805 12 4242, customersupport@rohde-schwarz.com
USA and Canada: +1-888-837-8772, customer.support@rsa.rohde-schwarz.com
Asia: +65 65 130 488, customersupport.asia@rohde-schwarz.com